

APF 15/50

FORWARD MOVING VIBRATORY PLATE



COMFORT AND OUTPUT

The APF 15/50 combines the powerful Ammann exciter system with industry-leading low hand-arm vibration (HAV) levels. The result is a powerful compactor that's comfortable and safe for operators, too. The APF 15/50 is able to utilise key options that can be mounted completely toolless. An optional Vulcolan mat, provides quick adjustment when working with paving stones while the water tank with included sprinkling system enables work on asphalt. The plate features a working width of 500 mm (19.7 in) and engine power of 2.6 kW (3.5 HP).

SIMPLE OPERATION

- Operator safety with low HAV levels (below 2.5 m/sec²)
- Machine frame that enables secure grip
- Great maneuverability boosts accuracy and makes work simple

POWERFUL COMPACTOR

- Generously sized, powerful exciter unit
- Leading compaction power, speed, climbing ability and machine life
- Compact dimensions allow use on sites with limited space

READY FOR RENTAL

- Low cost upkeep for owners
- Good match for many applications
- Easy for new users to operate

SERVICEABILITY

- Maintenance-free exciter system with cylindrical bearings
- Full engine protection frame
- Toolless daily maintenance

VERSATILE OPTIONS

- Toolless mountable water tank and sprinkler system
- Toolless mountable rubber mats to change onto paving stones
- Permanently mounted transport wheels easy relocation of the machine on site

APPLICATIONS

- Compaction in confined areas
- Asphalt and paving applications
- Light to medium patchwork
- Pipeline and trench construction
- Landscaping and gardening
- Earthwork

AMMANN

TECHNICAL SPECIFICATIONS
APF 15/50 FORWARD MOVING VIBRATORY PLATE

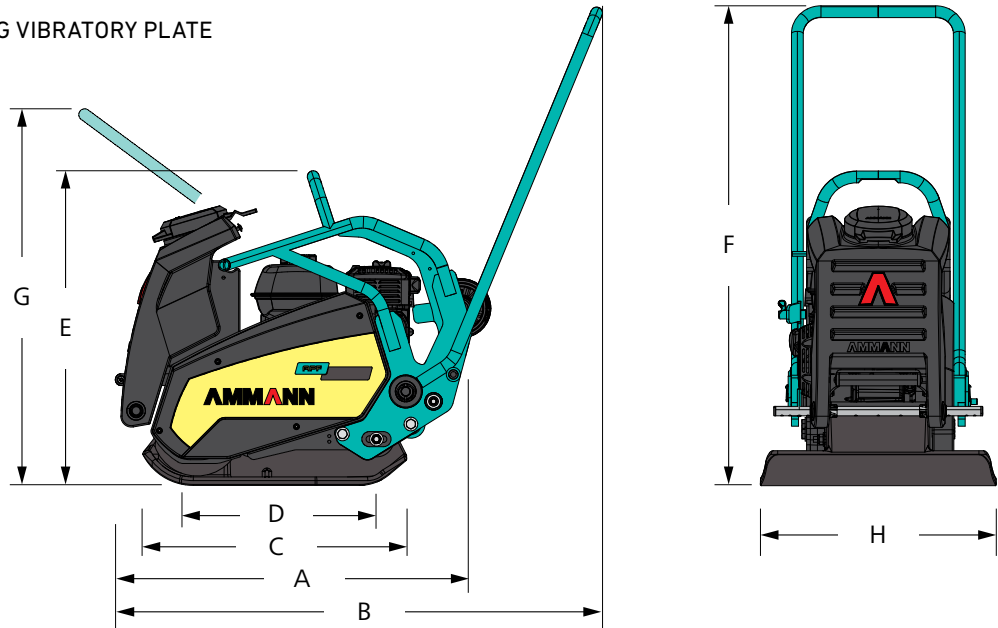

DIMENSIONS & WEIGHTS

MACHINE WEIGHT	84 kg (185 lb)
MACHINE WEIGHT (INCL. OPTIONAL SPRINKLER & WHEELS)	93 kg (205 lb)
A MACHINE LENGTH	700 mm (27.6 in)
B MACHINE LENGTH WITH HANDLE	1020 mm (40.2 in)
C BASE PLATE LENGTH	559 mm (22.0 in)
D GROUND CONTACT LENGTH	352 mm (13.9 in)
E MACHINE HEIGHT	667 mm (26.3 in)
F WITH HANDLE (WORK)	976 mm (38.4 in)
G WITH HANDLE (TRANSPORT)	736 mm (29.0 in)
H MACHINE WIDTH	500 mm (19.7 in)

COMPACTION FORCES

MAX. VIBRATION FREQUENCY	100 Hz (6000 vpm)
MAX. CENTRIFUGAL FORCE	15 kN (3372 lbf)
WORKING SURFACE	720 m ² /h (7750 ft ² /h)
SPEC. SURFACE PRESSURE	8,5 N/cm ² (12,4 psi)

ENGINE

ENGINE	Honda GX 120
FUEL	Petrol
ENGINE OUTPUT AT RPM	2.6 kW (3.5 HP) 3600

MISCELLANEOUS

HAND-ARM VIBRATION ON HANDLE	<2.5 m/s ²
SPEED	0–24 m/min (0–78.7 ft/min)
GRADEABILITY	30 %
MAX. INCLINE TO ALL SIDES	20°

OPTIONS

RUBBER MAT	x
TRANSPORT WHEELS	x
WATER SPRINKLER SYSTEM	12 l (3,2 gal)
HOUR METER	x

HIGHLIGHTS

- Low-vibration handle for operator safety and comfort
- Maintenance-free exciter system
- Base plate that is self cleaning and wear resistant
- Engine frame for protection on the jobsite and during transport
- Transport wheels, which can be dropped with a foot release and enable mobility on the jobsite